

# STYLELINE® HOLD OPEN REPLACEMENT

1. Remove door from frame.
  - Holding the top hinge pin with a  $\frac{5}{16}$ " wrench, loosen the lock nut with an  $\frac{11}{16}$ " wrench. This will release the spring tension.
  - Open the door and remove the two screws from the door plug. If a cord is present, unplug the cord from the frame.
  - With the door open about 90 degrees, lift the hold open cam off the slide pin.
  - Lift the door up and out off the bottom hinge pin.
2. Use a flat screwdriver to remove retaining clip, allowing cam to be removed from the pilot pin.

**CAUTION:** Note orientation of cam position.
3. Remove pivot pin from bottom of the door and the slide pin from the frame with a  $\frac{3}{4}$ " wrench.

**CAUTION:** Never remove more than one pin at a time from either the door or frame.
4. Hand-start the new pivot pin and the new slide pin; tighten both parts with a  $\frac{3}{4}$ " wrench to approximately 25 foot pounds.
5. Place new hold open cam onto pivot pin (orientation must be the same as before removal with offset toward frame). Hold cam in position and snap retaining clip in place with pliers.
6. Remove existing nylon washer from the hinge area and replace with the new washer.
7. Replace door by engaging top hinge pin into top bushing of door and lift door over bottom hinge pin, allowing door to drop into proper position.
8. Reconnect the door plug if it was removed.
9. Adjust door tension:
  - Using a  $\frac{5}{16}$ " wrench on top hinge pin, turn toward direction of door closing to increase tension.
  - Tighten top lock nut with an  $\frac{11}{16}$ " wrench.
  - Repeat above steps until desired tension is obtained.

**Installation is now complete.**

Open and close the door to check operation.

#### Tools Required:

- Flat Screwdriver
- $\frac{5}{16}$ " Wrench
- $\frac{11}{16}$ " Wrench
- $\frac{3}{4}$ " Wrench Pliers

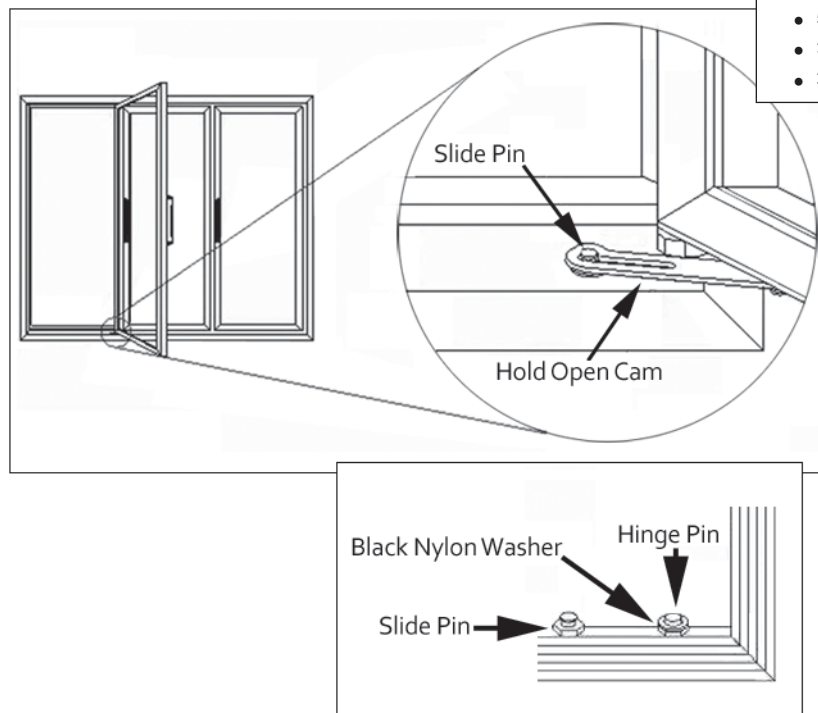

800-237-3940 • sales@STYLELINE.com • www.STYLELINE.com

